

AES RACKMOUNT

Energy Storage System

AES RACKMOUNT Slimline Enclosure Manual

READ AND SAVE THESE INSTRUCTIONS

AES RACKMOUNT Slimline Enclosure

950-0053

GUIDE FOR UL9540-COMPLIANT INSTALLATION 3

INTRODUCTION 5

1. AUDIENCE, WARNINGS, MESSAGES, GENERAL SAFETY, PERSONAL PROTECTIVE EQUIPMENT 5

 1.1 Audience 5

 1.2 Warning, Caution, Notice, and Note Messages 5

 1.3 Warnings and General Safety 6

 1.4 Safe Handling Procedures 6

 1.5 Personal Protective Equipment 7

 1.6 Emergency Procedure 7

2. ITEMS SHIPPED IN THE BOX 8

3. SPECIFICATIONS 8

 3.1 Electrical Specifications 8

 3.2 Mechanical Specifications 9

 3.3 Environmental Specifications 11

 3.4 Regulatory 11

4. TRANSPORTATION 11

5. HANDLING 11

6. FEATURES 12

7. SYSTEM OVERVIEW AND CONFIGURATION 13

 7.1 Minimum Specifications for AES RACKMOUNT Battery Energy Storage Systems 14

 7.2 Closed-loop Communication with Power Conversion Equipment 15

 7.3 Location 16

8. TOOLS 18

9. PREPARING THE ENCLOSURE FOR INSTALLATION 18

 9.1 Moving and Leveling the Enclosure 19

10. INSTALLATION 21

 10.1 Mounting the AES RACKMOUNT Battery Modules 21

 10.2 Connecting the Power Conversion Equipment 26

 10.3 Attaching the Plexiglass Busbar Protector 27

11. COMMISSIONING 28

12. ROUTINE INSPECTION 29

 12.1 External Parts of the Enclosure 29

 12.2 De-energize the Enclosure 30

 12.3 Internal Part of the Enclosure 30

13. OPTIONAL ACCESSORIES AND REPLACEMENT PARTS 31

14. RELATED INFORMATION 31

15. GLOSSARY 31

APPENDIX 32

 A1. AES RACKMOUNT BESS Commissioning Checklist 32

 A2. Decommissioning Checklist 36

GUIDE FOR UL9540-COMPLIANT INSTALLATION

| AES RACKMOUNT Slimline Enclosure | Description |
|---|---|
| Unit model number | 950-0053_X (X indicates the number of battery modules) |
| Battery Module model number | 48-48-5120 (900-0062) or 48-48-5120-H (900-0067) |
| Maximum capacity per unit | 30 kWh |
| Maximum number of battery modules per unit | 6 |
| Minimum separation from other ESS (sides) | 44.45 mm (1.75 in) |
| Minimum separation from other ESS (front to back) | 30.5 cm (12 in) |
| Minimum separation from other ESS (above/below) | Not applicable ⁽¹⁾ |
| Minimum separation from combustibile build constructions and other structures | 44.45 mm (1.75 in) |
| Exterior wall minimum separation from other ESS (side to side) | 44.45 mm (1.75 in) |
| Exterior wall minimum separation from other ESS (above/below) | Not applicable ⁽¹⁾ |
| Exterior wall minimum separation from other openings | 91.4 cm (36 in) |
| UL 9540 Edition | UL 9540 Edition 2 (TUV Rheinland, Report CN23N6RF 002, 11/10/2023) |
| UL9540A Testing Organization, Report, Date | TUV Rheinland, Report CN23AYBH 001, 05/15/2023 |
| Additional fire suppression required | None |
| Additional explosion protection | Minimum room volume of 35.8 m ³ (1270 ft ³) is required to maintain 25% or lower LFL ⁽²⁾ ⁽³⁾ |
| Other limitations | Listed for indoor or outdoor residential use. Units are intended to be installed in attached or detached garages, sheds, enclosed utility closets, basements, storage, or utility spaces within a dwelling. Not intended for installation in habitable and livings spaces in dwelling units. |

⁽¹⁾ The Enclosure is mounted on the ground. Installing an Enclosure above or below other Enclosures is not feasible.

⁽²⁾ The room volume protects against explosion in the unlikely event of a battery releasing explosive gases and entering thermal runaway. In normal operation, LiFePO₄ batteries do not release any hazardous gas.

⁽³⁾ If the room is smaller than prescribed, adding vents, deflagration vents, or a constantly running air circulation system could reduce the required room size. A certified safety engineer should determine the venting and volume of air circulation required.

| AES RACKMOUNT Slimline Enclosure | Description |
|---|--|
| Restrictions in Canada | Not allowed in dwellings. |
| Suitable for habitable spaces of dwellings? | No |
| Suitable locations | Residential |
| Limited access requirements | None |
| Environmental restrictions | Not suitable in locations exposed to salt spray, humid marine environments, or condensation. (Pending) AC 156 testing of fully loaded enclosure at Sds = 2.0 g. |
| Emergency Service Contact information | Infotrac: 1-800-535-5053 (Account # 115375) |
| DC ESS | The electrical ratings of connected power conversion equipment shall be compatible with Table 3-1, Electrical Specifications . |
| Residential smoke or heat alarm required? | Yes, when installed indoors as per local code. |

INTRODUCTION

The solid casing of the AES RACKMOUNT Slimline Enclosure is designed to withstand the harshest weather and host up to six AES RACKMOUNT battery modules for an energy storage system rated up to 30 kWh.

1. AUDIENCE, WARNINGS, MESSAGES, GENERAL SAFETY, PERSONAL PROTECTIVE EQUIPMENT

1.1 Audience

Configuration, installation, service, and routine inspections should only be performed by qualified personnel in consultation with local authorities having jurisdiction and authorized dealers. Qualified personnel should have training, knowledge, and experience in the:

- Installation of electrical equipment
- Application of electrical codes, safety, and installation standards
- Analysis and reduction of hazards involved in performing electrical work
- Installation and configuration of batteries.

1.2 Warning, Caution, Notice, and Note Messages

Messages in this manual are formatted according to this structure.

WARNING

Important information regarding hazardous conditions that may result in personal injury or death.

CAUTION

Important information regarding hazardous conditions that may result in personal injury.

NOTICE

Important information regarding conditions that may damage the equipment but not result in personal injury.

NOTE

Ad hoc information concerning important procedures and features unrelated to personal injury or equipment damage.

1.3 Warnings and General Safety

WARNING

ARC FLASH HAZARD

Before installation, service, or routine inspections, review the Arc Flash Warning label on the product.

Failure to follow these instructions may result in death or serious injury.

WARNING

ELECTRIC SHOCK AND FIRE HAZARD

Do not lay tools or other metal parts across battery terminals or internal components.

Failure to follow these instructions may result in death or serious injury.

CAUTION

ELECTRIC SHOCK HAZARD

- Do not touch the energized surfaces of any electrical component in the Enclosure.
- Before servicing the Enclosure, follow all procedures to fully de-energize the battery energy storage system. Refer to [12.2 De-energize the Enclosure](#).
- Follow "[Safe Handling Procedures](#)" when working with the Enclosure or battery energy storage system.

Failure to follow these instructions may result in injury.



Do not dispose of the product in a fire or the garbage.



This product is made of recyclable materials and should be recycled.

1.4 Safe Handling Procedures

Before using the Enclosure, read all instructions, cautionary markings on the unit, and all appropriate sections of this manual.

- Use personal protective equipment when working with the Enclosure.
- Do not wire battery modules or Enclosures in series.
- Dispose of or recycle a used Enclosure following local regulations.
- Do not modify the Enclosure except as specified by Discover Energy Systems.
- Do not immerse the Enclosure in water or other liquids.
- Do not expose the Enclosure to chemicals, fire, explosion, or other hazards.
- Only use the Enclosure with AES RACKMOUNT battery modules.
- Do not move the Enclosure while in operation.
- Lift, move, or mount the Enclosure following local regulations.

- Do not short-circuit the battery modules or busbar or allow metallic conductive objects to contact cable ends and terminals.
- Do not drop the Enclosure or battery modules.
- If the Enclosure or a battery module is damaged, take it to a service center for inspection.
- Do not expose the battery energy storage system (BESS) to high temperatures.

1.5 Personal Protective Equipment

When handling or working near a battery:

- Use Personal Protective Equipment, including clothing, glasses, insulated gloves, and steel-toe shoes.
- Do not wear metal rings, watches, bracelets, or necklaces.

1.6 Emergency Procedure

Unusual Odor

- If there is a burning smell:
 - Turn OFF the power conversion equipment.
 - Turn OFF (open the breakers) all the battery modules.
 - Call the installer and schedule an immediate inspection.

Fire

- If there is smoke or other signs of fire:
 - Call 911 (or the emergency phone number in your area).
 - If there is an emergency STOP button, press it to shut down the system.
 - Do not open the Enclosure door.
 - Do not attempt to put out the fire.
 - Do not spray water or other fire retardants.

2. ITEMS SHIPPED IN THE BOX

Table 2-1, AES RACKMOUNT Slimline Enclosure box contents

| ITEMS | DESCRIPTION |
|---------|--|
| 1 | AES RACKMOUNT Slimline Enclosure |
| 1 | Accessory kit with the following parts: <ul style="list-style-type: none"> • Keys (2) • CAT6 cable, 610 mm (24 in) (4) • Cable ties, 100 mm (4 in) (5) • Screws <ul style="list-style-type: none"> • M5 round-head screw (4) and washers • M6x14 hexagon-head screw (6) and washers • M6x30 hexagon-head screw (4) and washers • M8x25 hexagon-head screw (6) and washers |
| 6 pairs | Positive and negative battery cables. Length: 0.75 m (2.46 ft) |
| 1 | Busbar Mounting Assembly (Installed) |
| 1 | Busbar Plexiglass Protector |
| 6 | L-bracket |

3. SPECIFICATIONS

3.1 Electrical Specifications

Table 3-1, Electrical Specifications

| SPECIFICATION | VALUE |
|--|--|
| Nominal Voltage | 51.2 Vdc |
| Charge Voltage (maximum) | 55.2 Vdc |
| Input Current / Output Current (maximum) | 500 A |
| Energy Storage Capacity | 5 kWh per battery module (up to 30 kWh for six battery modules) |
| Output Available Fault Current | 3.8 kA / 100 ms per battery module (up to 22.8 kA / 100 ms for six battery modules) |
| Input Short Circuit Rating | 5 kA |

3.2 Mechanical Specifications

Table 3-2, Enclosure Dimensions

| DIMENSION | VALUE |
|---|-----------------------|
| Height | 1721 mm (67.76 inch) |
| Width | 350 mm (13.78 inch) |
| Depth | 680.0 mm (26.77 inch) |
| Depth (with handles) | 715.7 mm (28.18 inch) |
| Weight | 80 kg (176.37 lb) |
| Weight (fully loaded with battery modules, battery cables, busbar, and the LYNK II Gateway) | 360 kg (793.66 lb) |
| Roof angle | 1.87 ° |

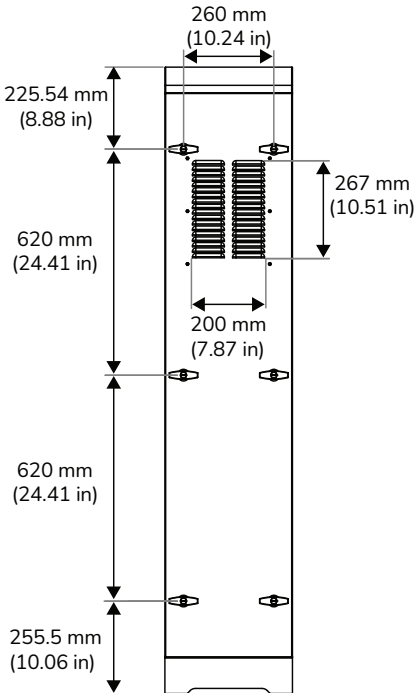

Figure 1. Front

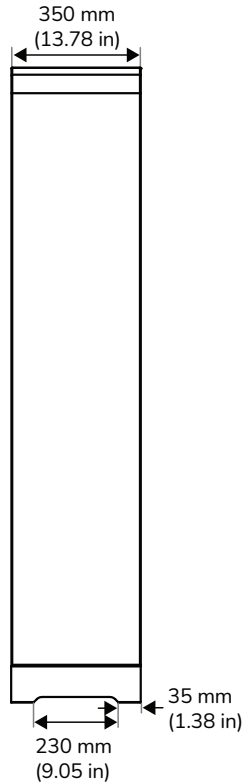

Figure 2. Back

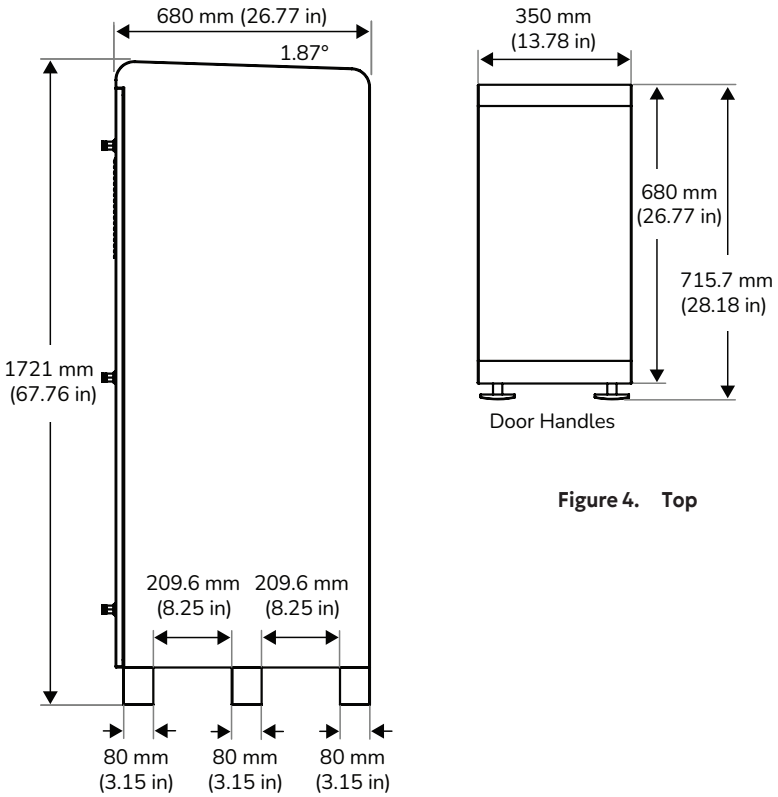

Figure 3. Side

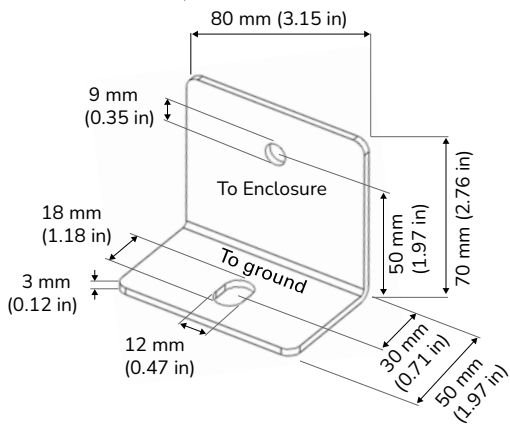

Figure 5. L-Bracket (for anchoring the Enclosure)

3.3 Environmental Specifications

Use the Enclosure and the AES RACKMOUNT battery modules either indoors or outdoors and away from living quarters.

| NOTICE |
|---|
| <ul style="list-style-type: none">• Do not install or operate in a location exposed to direct sunlight.• Do not install or operate near an open flame or heating source.• Do not install or operate in the living areas of the home or residence. |

| ENVIRONMENTAL SPECIFICATIONS | VALUE |
|-------------------------------------|----------------------------------|
| Charge Operating Temperature | 4°C to 52°C (39.2°F to 125.6°F) |
| Discharge Operating Temperature | -17°C to 52°C (1.4°F to 125.6°F) |
| Storage Temperature | -20°C to 55°C (-4°F to 131°F) |

3.4 Regulatory

| Regulatory |
|-------------------|
| UL 9540A |
| UL 9540 DC ESS |
| NEMA 3R |
| AC 156 (pending) |

4. TRANSPORTATION

Transport the Enclosure on the original pallet and in the original packaging or equivalent.

| NOTICE |
|--|
| Do not transport the AES RACKMOUNT Slimline Enclosure with battery modules installed. Ship the battery modules separately. |

5. HANDLING

Before handling:

- Do not immerse the Enclosure in water or other liquids.
- Keep the Enclosure away from chemicals, heat, and fire.
- Disconnect all cables from battery modules, power conversion equipment, and other power sources.
- Protect the battery module terminals from short-circuiting and touch.
- Do not lift or transport the Enclosure while in use or operation.
- Do not lift or transport the Enclosure by the attached cables.

6. FEATURES

Solid steel frame designed to withstand the harshest conditions.

The AES RACKMOUNT Slimline Enclosure can hold up to six AES RACKMOUNT battery modules in a configuration of 2 columns of 3 batteries. Each module is supported by the cross brackets of an internal cage and secured to the rack frame with screws.

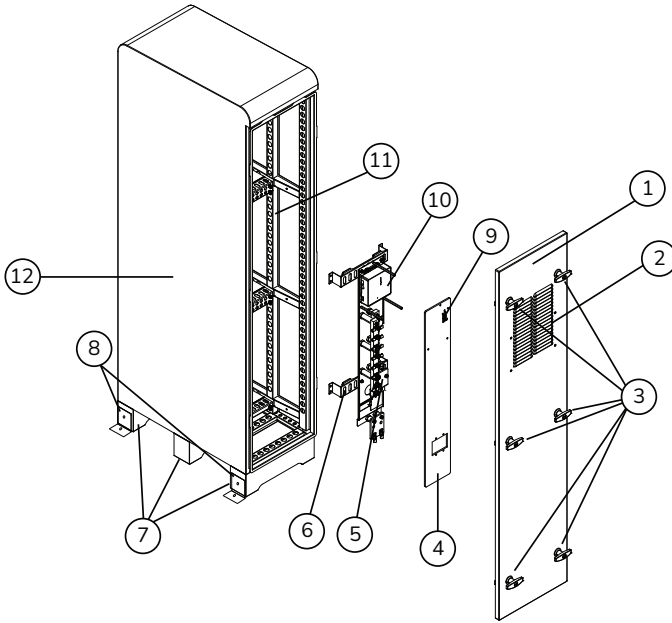

Figure 6. AES RACKMOUNT Slimline Enclosure Components

| ITEM | DESCRIPTION |
|------|---|
| 1 | Front Door |
| 2 | Air Vent (door with integrated fans is optional) ⁽¹⁾ |
| 3 | Door Handles (all with locks) |
| 4 | Plexiglass Busbar Protector |
| 5 | Positive and Negative Busbars |
| 6 | Busbar Mounting Assembly |
| 7 | Support Feet |
| 8 | L-brackets (for anchoring the Enclosure) |
| 9 | Remote Power ON/OFF Key |
| 10 | LYNK II Communication Gateway (not included) |
| 11 | Internal Cage |
| 12 | Enclosure |

⁽¹⁾ The door with integrated fans is not required to install and operate the Enclosure.

NOTE

- Configuration, installation, service, and routine inspections should only be performed by qualified personnel.
- Size fuses and breakers following established standards and have the system inspected by the local authority having jurisdiction.

7. SYSTEM OVERVIEW AND CONFIGURATION

The Enclosure can hold up to six AES RACKMOUNT battery modules in 2 columns of 3.

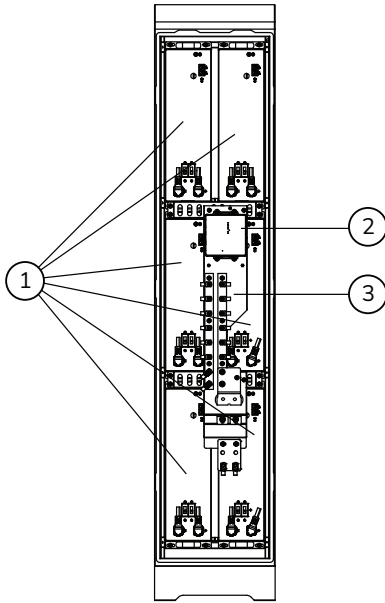

Figure 7. Two Columns of Three Battery Modules

| ITEM | DESCRIPTION |
|------|--|
| 1 | Up to 6 battery modules (not included) |
| 2 | LYNK II Gateway (not included) |
| 3 | Busbar Mounting Assembly and Plexiglass Busbar Protector (not shown) |

7.1 Minimum Specifications for AES RACKMOUNT Battery Energy Storage Systems

To increase system capacity, install AES RACKMOUNT battery modules in a parallel battery bank configuration. Overall battery energy storage system (BESS) capacity must be correctly sized to meet the requirements of the load and account for the following:

- Total Max Charge Current
- Total Peak Discharge Current
- Total Max Discharge Current

The total charging capacity of all charging sources in the system should not exceed the Max Charge Current operating limit of all the battery modules in the system. Exceeding this limit will cause the BMS in the battery modules to trigger over-current protection and disconnect. The charging system's maximum Continuous Charge Current must either be below the operating limit of installed battery modules or curtailed.

The sum of all the Peak Discharge Current values for the attached loads must be less than the Peak Current value of the BESS, including inrush current values for any motors and surge values for any inverters.

The sum of all the Max Discharge Current values for the attached loads must be less than that of the BESS.

For battery modules installed in parallel in a battery bank configuration, the sum of all battery module capacities provides the overall capacity value for the BESS. **Table 7-1** provides DC capacity values for sample systems using the AES RACKMOUNT battery modules.

NOTICE

- Exceeding the Peak Discharge Current, Max Discharge, or Max Charge values of the battery modules in the system will either trip the battery module Breaker or trigger the battery module BMS over-current protection, resulting in the disconnection of all battery modules in the system.
- Disconnection will result in a voltage spike (Load Dump), which may damage any component electrically attached to the battery energy storage system.

Table 7-1, 48-48-5120 / 48-48-5120-H DC Capacity Values for a Sample Battery Energy Storage System

Specifications @ 25 °C (77 °F)

| Part Number | Parallel System | Peak Current (3 seconds) | Max Discharge (1 hour) | Max Continuous Discharge (1) | Max Charge (1 hour) | Max Continuous Charge (1) | Usable Capacity |
|-------------|-------------------|--------------------------|------------------------|------------------------------|---------------------|---------------------------|-----------------|
| 950-0053_1 | 1 Battery Module | 218 A | 95 A | 70 A | 95 A | 70 A | 5 kWh |
| 950-0053_2 | 2 Battery Modules | 436 A | 190 A | 140 A | 190 A | 140 A | 10 kWh |
| 950-0053_3 | 3 Battery Modules | 654 A | 285 A | 210 A | 285 A | 210 A | 15 kWh |
| 950-0053_4 | 4 Battery Modules | 872 A | 380 A | 280 A | 380 A | 280 A | 20 kWh |
| 950-0053_5 | 5 Battery Modules | 1090 A | 475 A | 350 A | 475 A | 350 A | 25 kWh |
| 950-0053_6 | 6 Battery Modules | 1308 A | 500 A (2) | 420 A | 500 A (2) | 420 A | 30 kWh |

(1) The maximum continuous charge and discharge values are based on two complete charge and discharge cycles.

(2) The busbar is rated for 500 A. Do not exceed when charging or discharging the battery modules.

7.2 Closed-loop Communication with Power Conversion Equipment

NOTE

Closed-loop communication is not required in the operation of the Enclosure. Closed-loop communication is available to improve the performance of batteries and the power conversion equipment.

Closed-loop communication optimizes the performance and safety of the AES RACKMOUNT battery modules with Power Conversion equipment (Inverter-charger/MPPT Controller controller).

For closed-loop communication with the Power Conversion equipment, network the battery modules to the LYNK II Communication Gateway, then connect the LYNK II Communication Gateway to the Power Conversion equipment (refer to the [805-0033 LYNK II Installation and Operation Manual](#)).

For instructions on installing and setting up closed-loop communication with Power Conversion equipment, refer to the specific LYNK II application note for the brand of Power Conversion equipment in use.

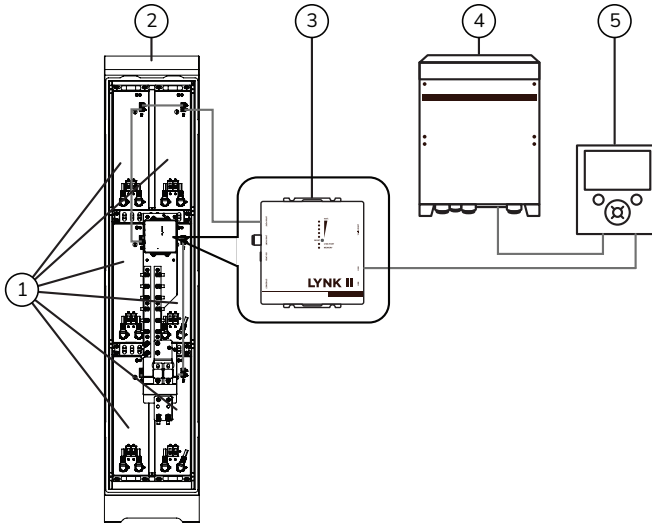

Figure 8. Example of the AES RACKMOUNT Slimline Enclosure in a Closed-Loop System

| ITEM | DESCRIPTION |
|------|--|
| 1 | Battery Modules |
| 2 | Enclosure |
| 3 | LYNK II Communication Gateway |
| 4 | Power Conversion System (Inverter-charger / MPPT Controller) |
| 5 | Power Conversion System Display |

NOTE

One LYNK Network can support up to 36 AES RACKMOUNT battery modules. The total length of the LYNK network cables must not exceed 36 m (118.11 ft). For configuration information, refer to the [LYNK II Installation and Operation Manual](#) (805-0033).

7.3 Location

The AES RACKMOUNT Slimline Enclosure can be used indoors ⁽¹⁾ or outdoors. If installed indoors, provide smoke or heat alarms in the vicinity in accordance with appropriate building, fire, and installation codes.

The installation location should be flat, free from debris, and separate from habitable and living areas. The location should allow for airflow, and ventilation is required. The ground of the preferred location should have at least 5 cm (2 inches) thick concrete to enable the use of concrete screws for anchoring the Enclosure.

Avoid installing in locations exposed to salt spray, humid marine environments, or condensation.

⁽¹⁾ The Enclosure is intended to be suitable for residential installations per UL 9540 clause 42.14.

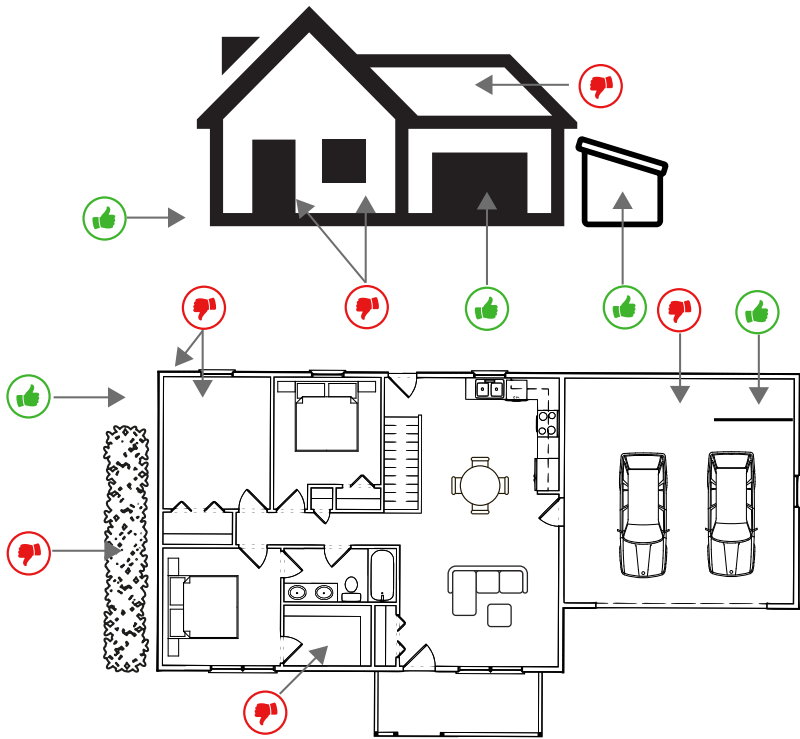

Figure 9. Installation Locations

Consider the following, as well as local fire and building codes, when determining the installation location:

1. **Locate away from habitable and living areas.** Install the Enclosure in a shed, attached or detached garage, or outdoors. Do not install in or within 152.4 cm (5 ft) of habitable and living spaces, including bathrooms, closets, halls, and storage spaces. If installed in a garage, either locate the energy storage system so a vehicle cannot collide with it or protect the energy storage system with a barrier. If installed and operated outdoors, do not locate within 1 meter (3 feet) of doors or windows.
2. **Flat Surface.** The installation surface should be flat and level with appropriate drainage. Do not install in locations prone to flooding.
3. **Away from direct sunlight.** Do not install or operate the Enclosure outdoors in an area exposed to direct sunlight. Install and operate in shaded areas opposite the sun's path.
4. **Moderate temperatures.** Install and operate in a location with ambient temperatures between 0°C and 40°C (32°F and 104°F). Ambient temperatures of 15°C to 20°C (59°F to 68°F) are ideal for extending LiFePO₄ battery life. If the installation environment experiences cold temperatures, use the battery model that includes heating.
5. **Ventilated.** Do not install the Enclosure in a zero-clearance compartment. Provide at least 44.45 mm (1.75 in) of clearance space at the top, front, back, and sides.

Add vents to allow airflow to the outdoors from the room that houses the Enclosure and Battery Modules.

6. **Room Size.** If installing in a structure, a room volume of at least 35.8 m³ (1270 ft³) is required to maintain 25% or lower LFL, to protect against explosion in the unlikely event of a battery releasing explosive gases and entering thermal runaway. In normal operation, LiFePO₄ batteries do not release any hazardous gas.
7. **No objects on the Enclosure.** Do not stack objects, components, or other Enclosures on top of the Enclosure.

8. TOOLS

- Insulated and settable torque driver with bits matched to the nuts, screws, and bolts in use
- Insulated screwdriver with bits matched to the screws in use
- Hydraulic knockout punch
- Insulated crimping tool
- RMS voltmeter
- Level
- Personal protective equipment

9. PREPARING THE ENCLOSURE FOR INSTALLATION

If any adjustments are required to the AES RACKMOUNT Slimline Enclosure, they should be made before installing the battery modules.

- Use a two-person lift to move the Enclosure to its final installation location.
- Punch out holes for DC loads, power conversion equipment, and communication cables.
- Anchor the Enclosure to the ground.
- Remove the busbar plexiglass protector and the busbar mounting assembly.

Use personal protective equipment, including gloves and appropriate footwear, when working with the Enclosure and battery modules.

NOTE

- To avoid damage and scratches to the Enclosure and its contents, do not lay the Enclosure on its side.
- The location of holes for DC loads, power conversion equipment, and communication should minimize exposure to the elements and minimize the ingress of moisture due to rain, snow, or flooding.
 - Consider knocking out the holes on the sides of the Enclosure, on the bottom third and closer to the door, to provide access to the Enclosure busbar connectors.
 - Use appropriate NEMA or IP-rated conduit fittings around holes to maintain the Enclosure's NEMA 3R rating.
 - Refer to applicable codes and standards set by the local authority having jurisdiction for the installation of external power conversion equipment. In North America, refer to NFPA 70 and C22.1.

9.1 Moving and Leveling the Enclosure

⚠ CAUTION

HEAVY OBJECT

The Enclosure is very heavy once fully loaded. Do not move it after it is loaded.

Failure to follow these instructions may result in injury.

1. Turn all the handles to their horizontal position (open) and remove the Enclosure door. Be careful not to loosen the bonding wire between the door and the internal rack frame.
2. Inside the Enclosure, find the accessory kit and confirm its contents with [2. ITEMS SHIPPED IN THE BOX](#). Remove the kit and place the items to the side.
3. Attached to the internal cage is the busbar mounting assembly. Using a Phillips screwdriver, remove the screws securing the busbar mounting assembly to the internal cage, and place the busbar mounting assembly and screws to the side.
4. Lift the Enclosure upright.
5. Use a hydraulic knockout punch to punch holes for DC loads, power conversion equipment, and communication cables.

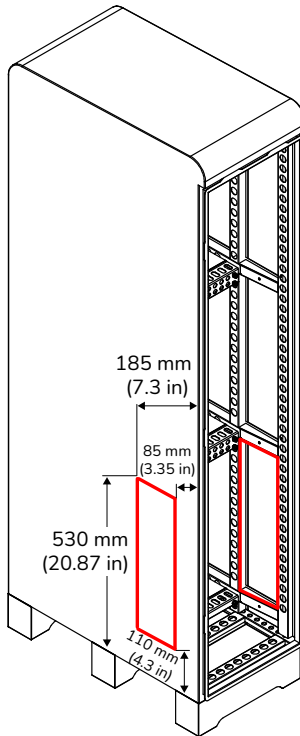

Figure 10. Dimensions of Area for Knockouts

To avoid damage to the internal frame, knock out the holes on the sides of the Enclosure 85 to 185 mm (3.35 to 7.3 in) from the front opening, and 110 to 530 mm (4.3 to 20.87 in) from the bottom of the Enclosure body. The location of holes should minimize exposure to the elements and minimize the ingress of moisture due to rain, snow, or flooding.

- Carefully move the Enclosure to its final installation location using a two-person lift.
- Ensure the Enclosure is level and balanced. Use shims if required.

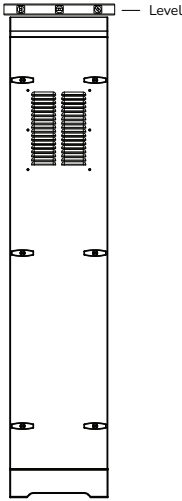

Figure 11. Level the Enclosure

- Drill holes into the concrete for anchoring the Enclosure.
- Using the M10 screws, attach the six L-brackets to the feet of the Enclosure with a torque of 21.4 Nm (15.8 lb-ft), then anchor the Enclosure to the ground with 3/8 inch (9.5 mm) concrete screws (not provided).

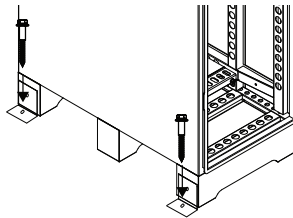

Figure 12. Anchor with Concrete Screws

NOTICE

- Do not put heavy objects on top of the Enclosure, as extra weight can damage the Enclosure, rack, or support feet. If damage occurs, unload the Enclosure and replace the damaged components.
- The AES RACKMOUNT Slimline Enclosure is very heavy when loaded with battery modules. It is, therefore, advisable to punch holes for home runs, and position, balance, and anchor the Enclosure before loading it with battery modules.
- If installing and operating multiple Enclosures, maintain a minimum space of 44.45 mm (1.75 in) between the sides and backs of each enclosure. More space may be required depending on the location of wires and grommets in the installation.

NOTE

The roof of the Enclosure slopes down 1.87 ° from front to back to reduce pooling of water and snow.

10. INSTALLATION

10.1 Mounting the AES RACKMOUNT Battery Modules

CAUTION

HEAVY OBJECT

- The Enclosure is very heavy once fully loaded. Do not move it after it is loaded.
- A two-person lift is recommended when installing the battery module into the Enclosure. A two-person lift reduces the likelihood of pinching fingers and skin between the battery module and the Enclosure.

Failure to follow these instructions may result in injury.

CAUTION

ELECTRICAL HAZARD

- Configuration, installation, service, and routine inspections should only be performed by qualified personnel.
- When installing the battery modules, orient the end with the breakers towards the bottom.
- Do not install in wet conditions.
- When connecting battery cables to the Enclosure's busbar, use only the busbar terminal screws. Do not connect the battery cables with screws intended to hold the busbar mounting assembly to the Enclosure's internal cage.

Failure to follow these instructions may result in injury.

In the order shown below, install the AES RACKMOUNT battery modules into the Enclosure with their breakers oriented toward the bottom. For detailed instructions, refer to the [AES RACKMOUNT Installation and Operation Manual](#) (805-0043).

1. Confirm the Enclosure is in its final position.

Moving the Enclosure after it is loaded with battery modules is dangerous. You may damage parts of the Enclosure, including its base, screws, internal cage, and Enclosure walls.

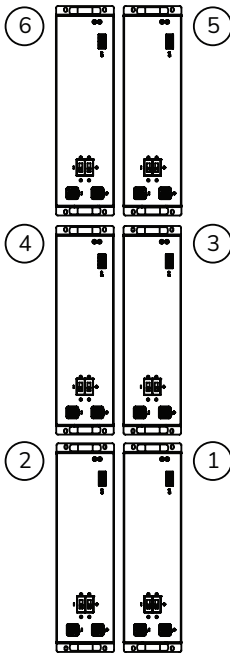
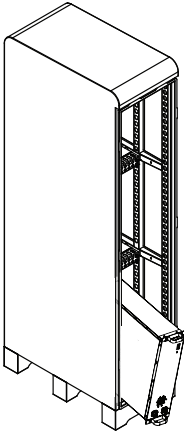

Figure 13. Order of Installation

2. Starting from the bottom, install the battery modules in the order indicated. The position of the breakers should be at the bottom.

- a. (Optional) Apply masking tape on the bottom, front edge of the Enclosure to protect it from scuffs and scratches that could appear when inserting batteries.
- b. Holding the front end of the battery module higher, carry the battery module into the Enclosure using a two-person lift.
- c. Carry the battery module as deep as you can into the Enclosure, then lower the back end of the body onto the edge of the internal cage.



Readjust your hands and lift the battery module the rest of the way into the Enclosure, carefully lowering it into position along the rails and pushing the battery module right to the back without cracking the plastic sheet on the bottom.

Figure 14. Inserting the Battery Module into the Enclosure

3. Repeat until all the batteries are inserted into the Enclosure.
4. Secure the battery modules to the rack frame with the M6 screws using a torque of 8 to 10 Nm (5.9 to 7.4 ft/lb). Insert all the screws except for screw locations marked in **RED** (see the following diagram). The screws in these locations secure both the battery module and the busbar mounting assembly.
5. Referencing instructions in the [AES RACKMOUNT Installation and Owners Manual \(805-0043\)](#):
 - a. Ground each battery module to the grounding screws on the sides of the rack frame, as well as the bonding wire from the internal rack frame to the door. Use torque of 7 to 8 Nm (5.16 to 5.9 ft-lb).

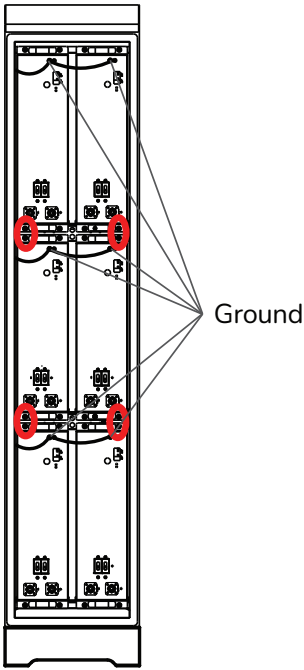

Figure 15. Ground Battery Modules to the Enclosure

- b. Confirm the bonding wire connection to the internal rack frame has not been disconnected. Reconnect, if required.
- c. Use CAT5e or higher cables to network the battery modules.

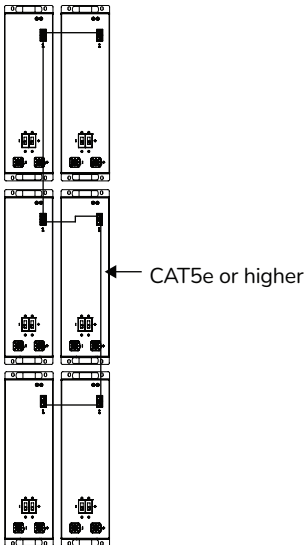

Figure 16. Network the Battery Modules

6. Prepare the busbar mounting assembly.
 - Three pegs jutting out from the busbar mounting assembly hold the Plexiglass Busbar Protector in place. Remove the screws from the pegs, then remove the Plexiglass Busbar Protector. Put the plexiglass to the side.
 - If using a LYNK II Gateway in the system, attach it to the busbar mounting assembly as shown in Figure 17.

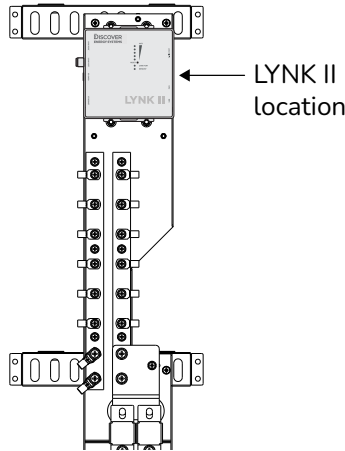

Figure 17. Attach LYNK II to Busbar Mounting Assembly

7. After the busbar mounting assembly is prepared, have one person stand in front of the Enclosure and hold the busbar mounting assembly while another person connects the battery cables from the busbar to the terminals on each battery module.

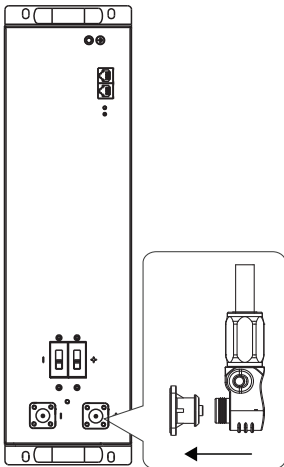

Figure 18. Battery Cable Connection

Attach the red, positive (+) cable connector to the red, positive (+) terminal on the battery module and push to lock the connector to the terminal. Attach the black, negative (-) cable connector to the black, negative (-) terminal on the battery module and push to lock the connector to the terminal.

8. After all the battery cables are connected, re-attach the busbar mounting assembly to the internal rack frame of the Enclosure with M6 screws, using a torque of 8 to 10 Nm (5.9 to 7.4 ft/lb).
9. Confirm the terminal bolts securing the battery cables to the busbar are tightened to a maximum torque of 8 to 10 Nm (5.9 to 7.4 ft/lb).

10.2 Connecting the Power Conversion Equipment

After positioning the Enclosure loaded with battery modules, and connecting the battery cables, connect the power conversion cables from the Power Conversion system to the AES RACKMOUNT Slimline Enclosure. For detailed instructions, reference the Power Conversion system documentation and the [AES RACKMOUNT Installation and Operation Manual](#) (805-0043).

⚠ WARNING

ELECTRIC SHOCK AND FIRE HAZARD

- Configuration, installation, service, and routine inspections should only be performed by qualified personnel.
- The home-run cables between the power conversion equipment and the AES RACKMOUNT Slimline Enclosure must be sized to handle the applicable loads as specified in [7.1 Minimum Specifications for AES RACKMOUNT Battery Energy Storage Systems](#) and the applicable manuals of the power conversion equipment.
- Size fuses, breakers, and cables following established standards and have the system inspected by the local authority having jurisdiction.

Failure to follow these instructions may result in death or serious injury.

1. Turn off the power on the batteries, power conversion equipment, and peripherals.
2. Attach appropriately sized fuses or breakers.
3. Connect the positive home-run cable to the inverter-charger, then connect the other end to the positive busbar on the Slimline Enclosure. Tighten the terminal bolts to a maximum torque of 15 Nm (11.1 ft/lb) on the busbar.
4. Connect the negative home-run cables to the inverters, then connect the other end to the negative busbar on the Slimline Enclosure. Tighten the terminal bolts to a maximum torque of 15 Nm (11.1 ft/lb) on the busbar.

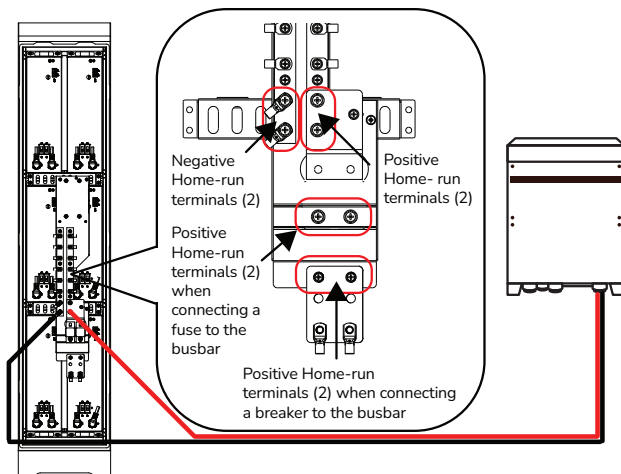

Figure 19. Wiring from Enclosure Busbar to Power Conversion Equipment

5. Install protection in the positive cable. The protection should be either a disconnect or fuse located close to the busbar's home-run terminal.
Local codes may limit how far the protection can be from the battery energy storage system.

NOTE

- Local codes and regulations may require the disconnect in both the positive and negative cables. Refer to the Local Authority Having Jurisdiction.
- AC circuit breakers and DC circuit breakers are not interchangeable. Check the label on the circuit breaker to ensure it is the correct type and rating. Use only DC circuit breakers.

10.3 Attaching the Plexiglass Busbar Protector

1. Screw in the Plexiglass Busbar Protector to the pegs jutting out from the busbar mounting assembly.

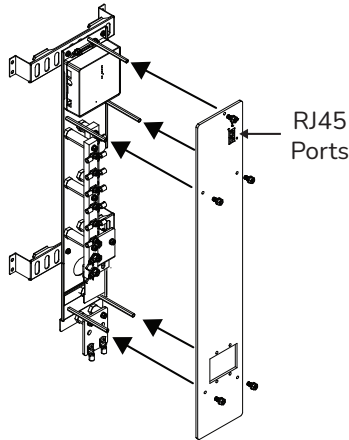

Figure 20. Attach Plexiglass Busbar Protector

2. Attach a CAT5e or higher cable from one of the battery modules to an RJ45 port on the Remote Power ON/OFF Key.
3. Attach a CAT5e or higher cable from the other RJ45 port on the Remote Power ON/OFF Key to the LYNK port on the LYNK II.

10.3.1 Remote Power ON/OFF Key Operation

WARNING

ELECTRIC SHOCK HAZARD

- The Remote Power ON/OFF Key does not disconnect the Power Conversion system. Keep your hands behind the plexiglass busbar protector and away from the busbars and battery cables as they may be carrying current.
- Do not touch the energized surfaces of any electrical component in the Enclosure.

Failure to follow these instructions may result in death or serious injury.

Turning All the Battery Modules ON or OFF

1. Briefly pressing the Enclosure's Remote Power ON/OFF Key inverts the state of connected Battery Modules.

The Remote Power ON/OFF Key will function correctly when:

- The Battery Modules are all connected in parallel over the busbar.
- The Battery Modules and the Remote Power ON/OFF Key are all networked together on the LYNK network with CAT5e or higher cables through the LYNK ports on the Battery Modules and LYNK II Gateway and the RJ45 port on the Remote Power ON/OFF Key.

Synchronizing the ON/OFF State of Battery Modules

If the states of the Battery Modules are not synchronized, perform the following to switch all the Battery Modules to OFF.

1. Press and hold the Remote Power ON/OFF Key for five or more seconds to trigger all the Battery Modules to switch ON.
2. Release the Remote Power ON/OFF Key and all the Battery Modules are switched OFF.

The Remote Power ON/OFF Key is now programmed to change all the Battery Modules to ON the next time the Remote Power ON/OFF Key is pressed.

11. COMMISSIONING

WARNING

ELECTRIC SHOCK HAZARD

- Use Personal Protective Equipment, including clothing, glasses, insulated gloves, and steel-toe shoes.
- Keep your hands away from the busbars and battery cables as they may be carrying current.
- Do not touch the energized surfaces of any electrical component in the Enclosure.

Failure to follow these instructions may result in death or serious injury.

1. Review the Commissioning checklist (see [A1](#)) before turning on the system.
2. Turn on one battery module and wait 30 seconds. Confirm it stays on without any errors.
3. Turn on the next battery module, and wait 30 seconds. Confirm it stays on without any errors.
4. Continue turning on all the battery modules until all the battery modules are on.

NOTICE

If a battery module faults during this sequence:

- Check the polarity of the battery cable connections on the busbars and the battery module.
- The SOC of the battery module may be different compared to the other battery modules. Try turning on the battery module again after waiting a few minutes.

12. ROUTINE INSPECTION

CAUTION

ELECTRIC SHOCK HAZARD

- Configuration, installation, service, and routine inspections should only be performed by qualified personnel.
- Do not open the door for service or inspections in wet conditions.
- Do not touch the energized surfaces of any electrical component in the Enclosure.
- Follow all procedures to fully de-energize the energy storage system.
- Follow the Safe Handling Procedures prescribed in all relevant manuals of the battery energy storage system.

Failure to follow these instructions may result in injury.

Inspect the Enclosure every 6 months.

12.1 External Parts of the Enclosure

1. Ensure the Enclosure is stable and all feet sit firmly on the mounting surface.
2. Inspect the anchoring mechanism for signs of rust or damage, and ensure all fasteners are tight.
3. Inspect the rest of the Enclosure, connections, and conduits for rust or damage.
4. Clean around the outside of the Enclosure.
5. Replace any rusted or damaged components.

12.2 De-energize the Enclosure

WARNING

ELECTRIC SHOCK HAZARD

- Configuration, installation, service, and routine inspections should only be performed by qualified personnel.
- Do not touch the energized surfaces of any electrical component in the Enclosure.
- Before servicing the Enclosure, follow the steps below to fully de-energize the battery energy storage system.

Failure to follow these instructions may result in death or serious injury.

1. Isolate the Enclosure from external power sources by opening all the disconnects of externally connected equipment, such as inverters, battery chargers, and charge controllers.
2. Open and remove the Enclosure door.
3. Turn off all the batteries and open all battery breakers.
4. Use a voltmeter to confirm there is no voltage across the positive and negative busbars.
5. Remove the plexiglass busbar protector.

12.3 Internal Part of the Enclosure

1. Look for any signs of water or condensation in and around the Enclosure.
2. Replace any aged, damaged, or rusted components.
3. Inspect in and around the Enclosure for any signs of animals or insects, such as chewed wires, nests, animal droppings, and webs.
4. Close off the mode of entry into the Enclosure by the animals or insects.
5. Confirm that all DC cables and connections on the busbar are secure and torqued to their specifications.
6. Inspect and clean network and battery connectors of dirt and debris.
7. Ensure all networking cables and connectors are secure and tight.
8. Ensure that the installation location is clean and free from debris.
9. Inspect the casing of all battery modules for cracks, bulging, or other damage.
10. Replace any damaged battery modules.
11. Replace any frayed, cut, or damaged cables.
12. Re-install the plexiglass busbar protector and re-connect the CAT5e or higher cable to the RJ45 port on the Remote Power ON/OFF Key.
13. Close all battery breakers and turn on all the battery modules. Confirm the green status LED turns ON for all the battery modules. For the different colors of the status LED and their meaning, refer to the [AES RACKMOUNT Installation and Operation Manual](#) (805-0043).
14. Close and lock the Enclosure door.
15. Close the disconnects of externally connected equipment, such as inverters, battery chargers, and charge controllers.
16. Verify the system does not generate any faults.

13. OPTIONAL ACCESSORIES AND REPLACEMENT PARTS

The following are available for the AES RACKMOUNT Slimline Enclosure.

Table 13-1, Accessories and Replacement Parts

| ACCESSORY | PART NUMBER |
|--|--------------------------|
| AES RACKMOUNT Battery Module | 48-48-5120 900-0062 |
| AES RACKMOUNT Battery Module - Heated | 48-48-5120-H 900-0067 |
| LYNK II Communication Gateway | 950-0025 |
| AES RACKMOUNT Battery Terminal Connector Set | 950-0054 |
| AES RACKMOUNT Battery Module Combiner System Off Board - Service Kit (Remote ON/OFF Key) | 960-0057 |
| AES RACKMOUNT Slimline Enclosure - Fan Kit | 950-0064 |
| AES RACKMOUNT Slimline Enclosure - Replacement Door | 960-0051 |

14. RELATED INFORMATION

Find information about Discover Energy Systems at discoverenergysys.com.

15. GLOSSARY

| | |
|--|--|
| BESS Battery Energy Storage System | LFP LiFePO ₄ , Lithium Iron Phosphate |
| BMS Battery Management System | SOC State of Charge |
| DOD Depth of Discharge | VPC Volts per cell |
| ESS Energy Storage System | |

APPENDIX

A1. AES RACKMOUNT BESS Commissioning Checklist

Use this checklist to confirm the correct installation and function of the AES RACKMOUNT BESS during the commissioning of the complete energy storage system. This checklist is only for the installation and operation of the AES RACKMOUNT BESS. Further system-level functionality checks and tests must be performed once the full system is interconnected with the AES RACKMOUNT BESS to complete commissioning.

Battery Installation

| PROCEDURE | CHECK |
|--|-------|
| 1. Ensure that ALL battery modules are securely mounted into the cabinet. Verify that: | |
| • All FOUR battery mounting fasteners are tight | |
| 2. Ensure that all the Enclosure's feet properly support the cabinet's weight. Verify that: | |
| • All areas of the feet are making solid contact with the mounting surface. | |
| • The locking nuts for all the feet are tight. | |
| 3. Ensure that the cabinet is suitably anchored to the ground. | |
| 4. Ensure that the busbar mounting plate is securely fastened to the cabinet. | |
| 5. Ensure that the busbars are securely mounted to the busbar mounting plate. | |
| 6. Ensure that the battery lead ring connectors are fastened to the busbars of the correct polarity. Verify that: | |
| • Each battery module's positive leads (RED) are connected to the positive busbar (RED STANDOFFS) and not to the screws of the busbar mounting assembly. | |
| • Each battery terminal screw is torqued to 8-10 Nm (5.9-7.4 ft/lb). | |
| • Each battery module's negative leads (BLACK) are connected to the negative busbar (BLACK STANDOFFS) and not to the screws of the busbar mounting assembly. | |
| • Each battery terminal screw is torqued to 8-10 Nm (5.9-7.4 ft/lb). | |

| PROCEDURE | CHECK |
|---|-------|
| 7. Ensure each battery terminal connector is secure and of correct polarity. | |
| <ul style="list-style-type: none"> • Verify for each battery module that the positive connector (RED) is correctly installed on the positive battery terminal (RED and marked with a "+") | |
| <ul style="list-style-type: none"> • Verify for each battery module that the negative connector (BLACK) is correctly installed on the negative battery terminal (Black and marked with a "-") | |
| <ul style="list-style-type: none"> • Each battery terminal connector is latched in place. <p>Note: Push in the terminals until the latching mechanisms click in place. If correctly installed, the terminals should not come off without pressing the release button on the lead side connector.</p> | |
| 8. Ensure that the home-run cable ring connectors are fastened to the correct polarity of the busbars. Verify that: | |
| <ul style="list-style-type: none"> • The positive home-run cables (RED) for each piece of externally connected equipment are fastened to the positive busbar (RED STANDOFFS). | |
| <ul style="list-style-type: none"> • Each positive home-run terminal screw is torqued to 15 Nm (11.1 ft/lb). | |
| <ul style="list-style-type: none"> • The negative home-run cables (BLACK) for each piece of externally connected equipment are fastened to the negative busbar (BLACK STANDOFFS). | |
| <ul style="list-style-type: none"> • Each negative home-run terminal screw is torqued to 15 Nm (11.1 ft/lb). | |
| 9. Equipment is bonded as required per the local installation code. Verify that: | |
| <ul style="list-style-type: none"> • A suitable-sized bonding wire is reliably secured to the marked bonding terminal on the BESS. | |
| 10. DC ESS disconnect and overcurrent protection are installed. Verify that: | |
| <ul style="list-style-type: none"> • Overcurrent protection is suitably rated for min 60 Vdc, 350 A per DC output. | |
| <ul style="list-style-type: none"> • Overcurrent protection has an Interrupt Capacity of a minimum of 22.8 kA x the number of BESS systems in parallel. | |
| <ul style="list-style-type: none"> • Disconnect is rated for min 60 Vdc, and to operate under load of 250 A per DC output. | |
| <ul style="list-style-type: none"> • Disconnect protection has an Interrupt Capacity of a minimum of 22.8 kA x the number of BESS systems in parallel. | |

Battery Operation Verification

The safety functions inside the Enclosure to protect the batteries are solely provided by each UL 1973 certified AES RACKMOUNT battery module and its integral BMS (Battery Management System). No communication with any equipment external to the AES RACKMOUNT BESS is needed to operate the battery module's integral protection functions.

Verify the items below to confirm that the protection functions of the battery modules are working correctly.

| PROCEDURE | CHECK |
|--|-------|
| 1. Confirm that each battery breaker is OPEN, and turn on each battery module through the push button. Verify that: | |
| <ul style="list-style-type: none"> • The battery status LED turns ON and pulses AMBER NOTE: <ul style="list-style-type: none"> • If the LED does not turn, there is an issue with the battery module. Contact Technical Support. • If the LED turns GREEN, check if the battery breaker is OPEN. If it is open, contact Technical Support. • If the LED turns RED, there is a fault present. Use LYNK Access software to find details about the fault. | |
| 2. CLOSE each battery breaker, one by one. After each battery breaker is closed, verify that: | |
| <ul style="list-style-type: none"> • The battery status LED changes from pulsing AMBER to solid GREEN. NOTE: If the LED displays any other color, the battery module has an issue. Contact Technical Support. <ul style="list-style-type: none"> • Check that all previously ON battery modules still display a solid GREEN LED and that their breakers remain closed. | |

Final Steps

After verifying the battery functionality, follow the steps below to put the Slimline DC ESS into a safe state.

| PROCEDURE | CHECK |
|---|-------|
| 1. Install the plexiglass busbar protector. Verify that: | |
| <ul style="list-style-type: none">Using an insulated Philips screwdriver ensures that all the mounting screws of the plexiglass busbar protector are tight. | |
| 2. Close each battery breaker, one by one. As each battery breaker is closed, verify that: | |
| <ul style="list-style-type: none">The battery status LED turns from pulsing AMBER to solid GREEN. <p>NOTE: If the LED displays any other color, the battery module has an issue. Contact Technical Support.</p> <ul style="list-style-type: none">Check that all previously ON battery modules still display a solid GREEN LED and that their breakers remain closed. | |

A2. Decommissioning Checklist

This checklist should be used to ensure the correct installation and function of the AES RACKMOUNT Slimline Enclosure during decommissioning of a complete battery energy storage system. This checklist is only for the battery energy storage system; further system-level decommissioning procedures on the full system may be required. Refer to the manuals of connected DC loads, power conversion equipment, and other components in the system.

Disassemble, Recycle, and Dispose

| PROCEDURE | CHECK |
|--|-------|
| 1. Open disconnect devices to ensure there is no electrical connection to any externally connected Power Conversion Equipment. | |
| 2. De-energize internal busbars. | |
| a. Remove the Enclosure door. | |
| b. Turn off each battery module one by one using the battery ON/OFF push buttons. | |
| c. Use a multimeter to verify there is no voltage on the busbars. | |
| 3. Disassemble the unit. | |
| a. Remove the plexiglass busbar protector. | |
| b. Disconnect battery lead busbar connections and home-run connections. | |
| c. Remove the mounting screws from the busbar mounting assembly. | |
| d. Remove the busbar mounting assembly. | |
| e. Remove the battery mounting screws. | |
| f. Using a two-person lift, remove all the battery modules, one by one, starting from the top shelf and working your way down. | |
| g. Release the anchor holding the AES RACKMOUNT Slimline Enclosure in place. | |
| 4. Recycle or dispose of components. | |
| a. Recycle all recyclable components. | |
| b. Dispose of unrecyclable components following local waste disposal guidelines. | |